

CD Stud Welding

CONTACT AND GAP STUD WELD TOOLS

FEATURES AND BENEFITS

Precision-engineered for convenient setup and optimum performance

Lightweight, ergonomic design minimizes operator fatigue

Heat settings adjust fast and easily — without additional tools — simplifying operation for novice and experienced users

Gap models require no user intervention — generating gap distances automatically

Contact and gap tools provide immediate visual feedback on heat settings, eliminating operator guesswork



Image's contact and gap stud welding tools are precision-engineered for quick setup and optimum performance. Ergonomically designed, both tools offer "fit-like-a-glove" comfort, promote efficient welding, and increase productivity while reducing operator fatigue. Compact and lightweight, the weld tools can be used even in the tightest weld areas, and users can make adjustments easily and conveniently — on the fly — without additional tools.

Both models offer a unique adjustment feature that makes changing the plunge fast and effortless. Gap models generate the gap automatically, and do not require the operator to preset the gap or to lift the mechanism manually. The gap weld tools also feature a rear gap adjustment that works like a power drill clutch for simplified, quick setting changes. Contact models have a uniquely designed indicator LED, which gives users immediate visual feedback, eliminating any guesswork by the operator. These tools offer full range adjustment without changing any internal components, unlike competitive brands. Contact models are designed for compatibility with most stud welding power supplies.

CONTACT AND GAP STUD WELD TOOLS

MECHANICAL SPECIFICATIONS

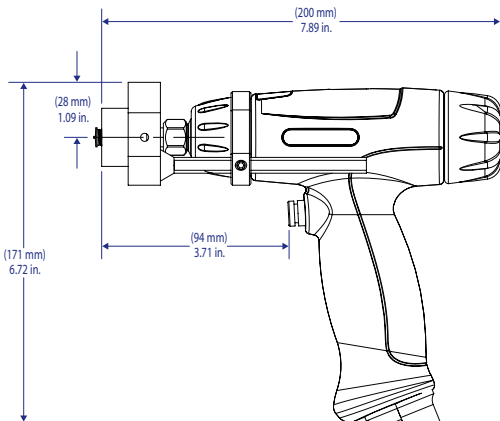

CL and GL Models
with a foot and spark shield

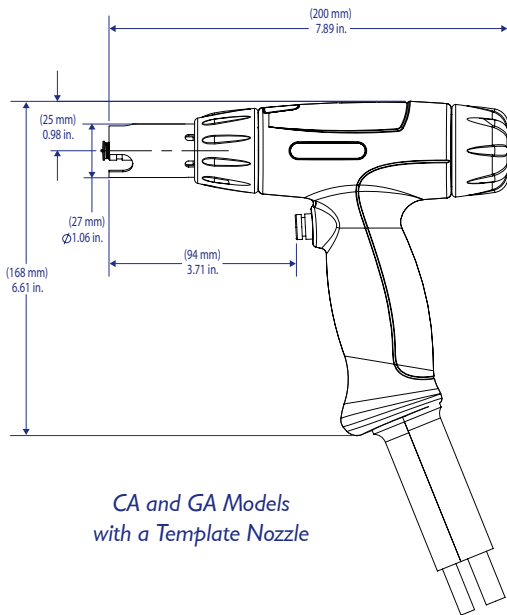

CA and GA Models
with a Template Nozzle

SPECIFICATIONS

Basic Weight:	1.9 lbs. (0.88 kg) Includes standard legs and foot, plus cable inside the gun
Stud Range Capacity:	14 gauge - 3/8" (3 mm - 10 mm)

ACCESSORIES

Standard Chuck Nut Wrench (GRM12)

Optional

Tripod Face Plate (GRM99)

Collets	#4 (CLI11)	#10 (CLI19)	3/8" (CLI37)	5 mm (CLIM5)
	#6 (CLI13)	1/4" (CLI25)	2 mm (CLIM2)	6 mm (CLIM6)
	#8 (CLI16)	5/16" (CLI31)	4 mm (CLIM4)	

WELD CONNECTORS

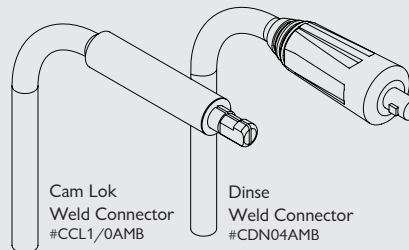

CONTROL CONNECTORS

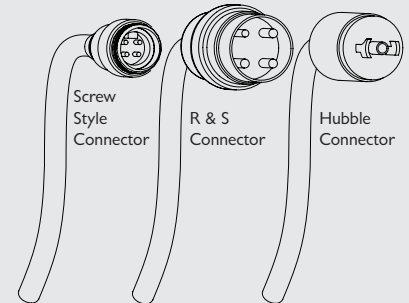

ORDERING INFORMATION

GA AND GL WELD TOOL PART NUMBERS

Weld Connector	GA CONTROL CONNECTOR			GL CONTROL CONNECTOR		
	Screw	R&S	Hubble	Screw	R&S	Hubble
Cam Lok	GRFAC-09	GRF2C-09	GRF6C-09	GRDAC-09	GRD2C-09	GRD6C-09
Dinse	GRFAZ-09	GRF2Z-09	GRF6Z-09	GRDAZ-09	GRD2Z-09	GRD6Z-09

CA AND CL WELD TOOL PART NUMBERS

Weld Connector	CA CONTROL CONNECTOR			CL CONTROL CONNECTOR		
	Screw	R&S	Hubble	Screw	R&S	Hubble
Cam Lok	GRCAC-15	GRC2C-15	GRC6C-15	GRAAC-15	GRA2C-15	GRA6C-15
Dinse	GRC AZ-15	GRC2Z-15	GRC6Z-15	GRAAZ-15	GRA2Z-15	GRA6Z-15

IMAGINATIVE SOLUTIONS FROM AN INDUSTRY LEADER

Contact and gap stud weld tools are the result of imaginative thinking and a commitment to provide our customers with reliable, easy-to-use stud welding equipment. As a technology-driven industry leader in stud welding, Image Industries continues to provide innovative, cost-effective solutions to your fastening challenges. We can provide everything you need — equipment, technical expertise, value-added solutions, and exceptional customer service — all from one company.

To learn more about contact and gap stud weld tools or to discuss your requirements, call us at (800) 722-7883.



IMAGE INDUSTRIES INC.

11220 E. Main Street • Huntley, IL 60142 USA
Tel: (847) 659-0100 • (800) 722-7883 • Fax: (847) 659-0108
www.imageindustries.com • email: sales@imageindustries.com