

Hydraulic Port Weld Stud

Image's Stud Weldable Hydraulic Ports Provide Extremely Strong, Leak Proof Welds onto Hydraulic Cylinders in Less than One Second

Image's stud weldable hydraulic ports allow far quicker, stronger welds onto hydraulic cylinders compared with the manual welding process. The stud weldable ports are easily welded onto hydraulic cylinders in less than one second, which can take from one to several minutes with manual welding. This dramatic time reduction will help hydraulic cylinder manufacturers increase their productivity and cut costs.

Stud weldable hydraulic ports permit a stronger weld with less heat distortion of the cylinder. The weld is structurally stronger because it is a full cross-sectional weld, which reduces failures and leaks. Heat distortion in the cylinder is minimized due to the fast welding time, which prevents heat build up within the cylinder. With less cylinder distortion, finishing operations are minimized.

Image's stud weldable hydraulic ports are all produced to custom specifications. These type of ports can be designed in a wide variety of configurations. Configurations can include straight or angled ports, internal or external threads. Ports can also be manufactured in a variety of sizes to meet customer's specifications.



Process Description:

The port is loaded into a stud welding tool. The tool is positioned against the cylinder. The weld sequence is initiated. The weld time varies with the size of the port. A typical weld time for a port with an outer wall dimension of 5/8" would be 0.6 seconds. The tool is removed from the port and the weld is complete. Because weld times are short, heat is only induced into a very localized area.

The port can now be drilled through (a pilot for the drill is typically designed into the port) into the cylinder. *Note: this is not an extra drilling operation, it just places the drilling operation after the weld instead of before the weld.* The subsequent finishing operations remain the same. Because the weld is a full cross-sectional weld seal integrity is excellent. Image has seen results of fewer than 1 leak in 50,000 welds.

Common Port Styles

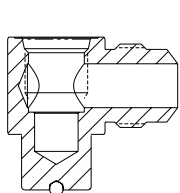

SECTION A-A

Right angle Male

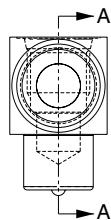

In-line Male

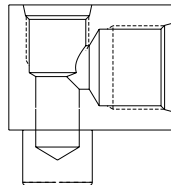
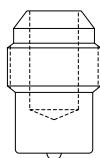

Right angle Female

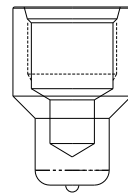
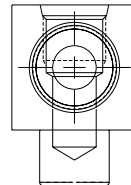

In-line Female



IMAGE INDUSTRIES INC.

382 Balm Court • Wood Dale, IL 60191 USA

Tel: (630) 766-7373 • (800) 722-7883 • Fax: (630) 766-2402

www.imageindustries.com • email: sales@imageindustries.com

Port Welding Process Comparison

Stud Weld Cylinder Process

Skive/Hone Cylinder

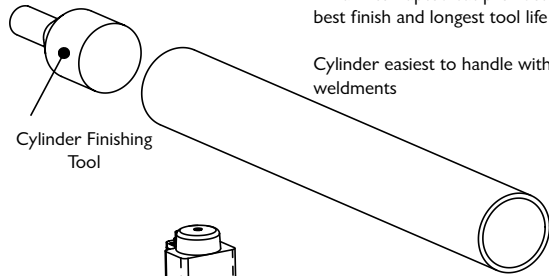

An uninterrupted cut provides best finish and longest tool life

Cylinder easiest to handle with no weldments

Weld Port

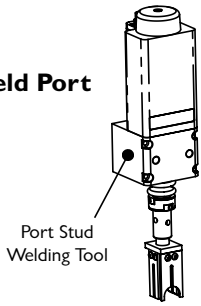

Port Stud Welding Tool

Weld time of .6 - 1 seconds. Saves \$ by increasing throughput.

Full cross-sectional weld, not a perimeter weld. Provides superior leak free results. Significant rework and \$ cost reduction.

One port fits a wide range of tube diameters. Fewer inventory items to stock and purchase.

Small heat affected zone

Small heat zone due to short weld times

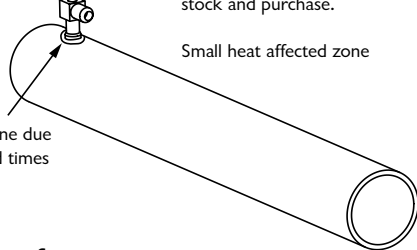

Drill & Chamfer

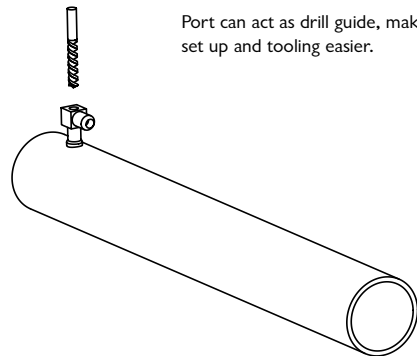

Port can act as drill guide, making set up and tooling easier.

Plug Weld Port

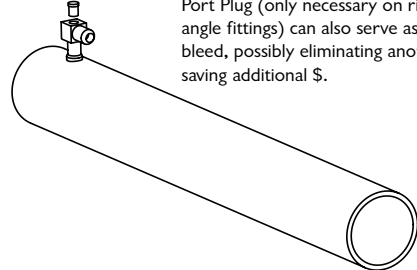

Port Plug (only necessary on right angle fittings) can also serve as an air bleed, possibly eliminating another port saving additional \$.

The stud weld process saves you \$ from higher production speed, reduced rework (higher quality) and longer tool life.

Traditional Cylinder Process

Drill & Chamfer

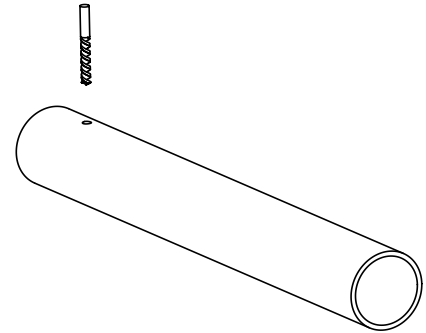

Weld Port

Weld time of 20-60 seconds

Manual or Automated Weld Around

Perimeter weld only which can be prone to leaks

Need to stock same boss with different radii to match different tube diameters

Large heat affected zone

Heat zone which may cause tube distortion and longer cylinder finishing operation.

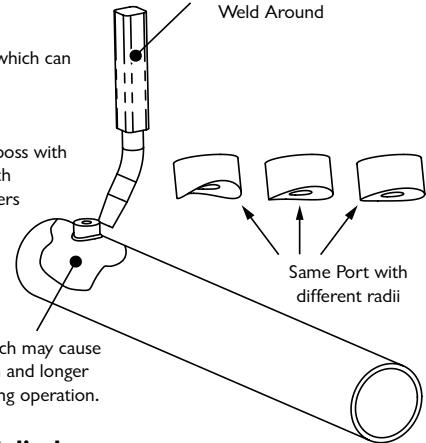

Skive/Hone Cylinder

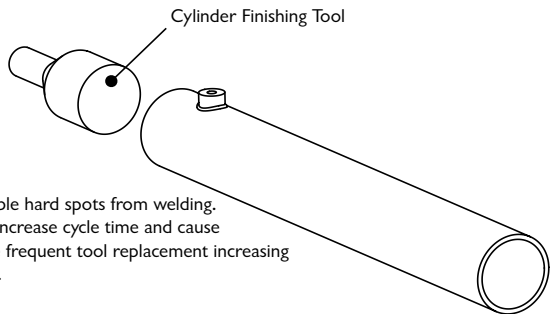

Cylinder Finishing Tool

Possible hard spots from welding. Can increase cycle time and cause more frequent tool replacement increasing costs.

Add Angle Fitting

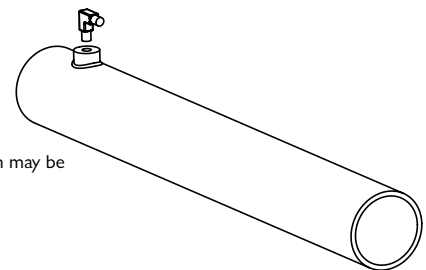

Consistent orientation may be a quality concern.