

ARC WELD Studs

Reduced Base Mild Steel

| | | BODY DIAMETER & THREAD PITCH | | | | | |
|---|-----------------|-------------------------------|------------|------------|------------|------------|------------|
| | | 1/4-20 | 5/16-18 | 3/8-16 | 1/2-13 | 5/8-11 | 3/4-10 |
| Example Part No. | | RBC25-62 | RBC31-62 | RBC37-62 | RBC50-1 | RBC62-162 | RBC75-162 |
| Min Length | | .625" | .625" | .625" | 1" | 1.625" | 1.625" |
| Max Length | | Most sizes are made to order. | | | | | |
| Base | Length | .187 | .187 | .375 | .437 | .550 | .800 |
| | Diameter | .187" | .272" | .312" | .437" | .500" | .620" |
| Fillet | Height | .12 ± .02" | .12 ± .02" | .12 ± .02" | .15 ± .02" | .17 ± .02" | .28 ± .02" |
| | Diameter | .28 ± .02" | .34 ± .02" | .41 ± .02" | .53 ± .02" | .66 ± .02" | .77 ± .02" |
| After Weld Length Reduction (approx) | | .12" | .12" | .12" | .12" | .19" | .19" |

| STANDARD ACCESSORIES | | | | | | |
|----------------------|-------|-------|-------|-------|-------|-------|
| Chuck | C25 | C31 | C37 | C50 | C62 | C75 |
| Grip | G25 | G31 | G37 | G50 | G62 | G62 |
| Foot | FTS20 | FTS20 | FTS20 | FTS20 | FTM20 | FTM20 |
| Ferrule | 25T | 31T | 37T | 50T | 62RB | 62F |

| MECHANICAL PROPERTIES | | | | | | |
|---|-----------|-----------|------------|------------|------------|-------------|
| (see appendix tables for calculation details particularly when comparing different manufacturers) | | | | | | |
| Min Working Tensile | 907 lb | 1,527 lb | 2,291 lb | 4,241 lb | 6,814 lb | 10,189 lb |
| Min Yield Shear | 775 lb | 1,305 lb | 1,959 lb | 3,625 lb | 5,824 lb | 8,710 lb |
| Min Working Torque | 3.8 ft•lb | 8.0 ft•lb | 14.3 ft•lb | 35.3 ft•lb | 71.0 ft•lb | 127.4 ft•lb |
| Min Yield Torque | 4.5 ft•lb | 9.5 ft•lb | 17.2 ft•lb | 42.4 ft•lb | 85.2 ft•lb | 152.8 ft•lb |

A Reduced Base Stud has a smaller diameter base than any other stud of equal thread diameter. This style of stud is frequently used when the mating part tolerances are very tight and can not accomodate the extra fillet diameter of a Pitch Diameter or Full Thread Stud. Because of the extra processing involved, a Reduced Base Stud is typically more expensive than an equivalent Pitch Diameter or Full Thread Stud. Also, because the base is reduced in diameter the mechanical properties of the fastener are lower than for the equivalent thread size in either Pitch Diameter or Full Thread Studs.



IMAGE INDUSTRIES INC.

382 Balm Court • Wood Dale, IL 60191 USA

Tel: (630) 766-7373 • (800) 722-7883 • Fax: (630) 766-2402

Reduced Base Stainless Steel

DRAWN ARC WELD STUD

| | BODY DIAMETER & THREAD PITCH | | | | | |
|---|-------------------------------|------------|------------|------------|------------|------------|
| | 1/4-20 | 5/16-18 | 3/8-16 | 1/2-13 | 5/8-11 | 3/4-10 |
| Example Part No. | RBS25-62 | RBS31-62 | RBS37-62 | RBS50-1 | RBS62-162 | RBS75-162 |
| Min Length | .625" | .625" | .625" | 1" | 1.625" | 1.625" |
| Max Length | Most sizes are made to order. | | | | | |
| Base | Length | .187 | .187 | .375 | .437 | .550 |
| | Diameter | .187" | .272" | .312" | .437" | .500" |
| Fillet | Height | .12 ± .02" | .12 ± .02" | .12 ± .02" | .15 ± .02" | .17 ± .02" |
| | Diameter | .28 ± .02" | .34 ± .02" | .41 ± .02" | .53 ± .02" | .66 ± .02" |
| After Weld Length Reduction (approx) | .12" | .12" | .12" | .12" | .19" | .19" |

| STANDARD ACCESSORIES | | | | | | |
|----------------------|-------|-------|-------|-------|-------|-------|
| Chuck | C25 | C31 | C37 | C50 | C62 | C75 |
| Grip | G25 | G31 | G37 | G50 | G62 | G62 |
| Foot | FTS20 | FTS20 | FTS20 | FTS20 | FTM20 | FTM20 |
| Ferrule | 25T | 31T | 37T | 50T | 62RB | 62F |

| MECHANICAL PROPERTIES | | | | | | |
|---|-----------|-----------|------------|------------|------------|------------|
| (see appendix tables for calculation details particularly when comparing different manufacturers) | | | | | | |
| Min Working Tensile | 544 lb | 916 lb | 1,375 lb | 2,545 lb | 4,088 lb | 6,114 lb |
| Min Yield Shear | 465 lb | 783 lb | 1,175 lb | 2,175 lb | 3,495 lb | 5,226 lb |
| Min Working Torque | 2.3 ft•lb | 4.8 ft•lb | 8.6 ft•lb | 21.2 ft•lb | 42.6 ft•lb | 76.4 ft•lb |
| Min Yield Torque | 2.7 ft•lb | 5.7 ft•lb | 10.3 ft•lb | 25.4 ft•lb | 51.1 ft•lb | 91.7 ft•lb |

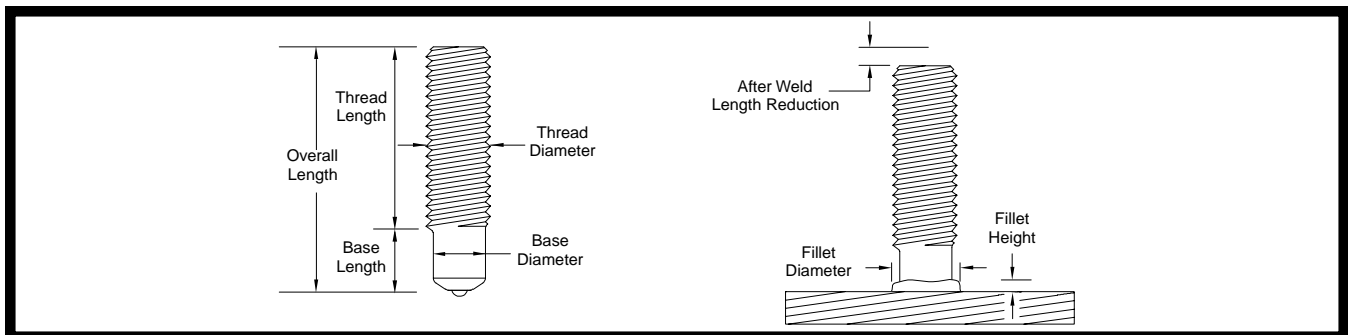

IMAGE INDUSTRIES INC.

382 Balm Court • Wood Dale, IL 60191 USA

Tel: (630) 766-7373 • (800) 722-7883 • Fax: (630) 766-2402